



## Velo Steel Cycle Shelter



Our **Velo cycle shelter** is based on a simple modular design which is suitable for almost any application. Its features include:

- Vast range of configurations and customisation available, including compounds and hinged or sliding gates.
- Unlimited and bespoke lengths possible
- Offers excellent value for money and durability.

### Material specification:

Manufactured from durable galvanised, powdercoated steel in accordance with EN 10219:2006 High quality PET-G UV2 polycarbonate roof sheets  
Powdercoated to BS3900 with a wide range of colours available.  
Cloaking (if required) provides an aesthetically pleasing and more durable finish  
Choice of cycle hoops or scooter racks available, in galvanised or powdercoated finish

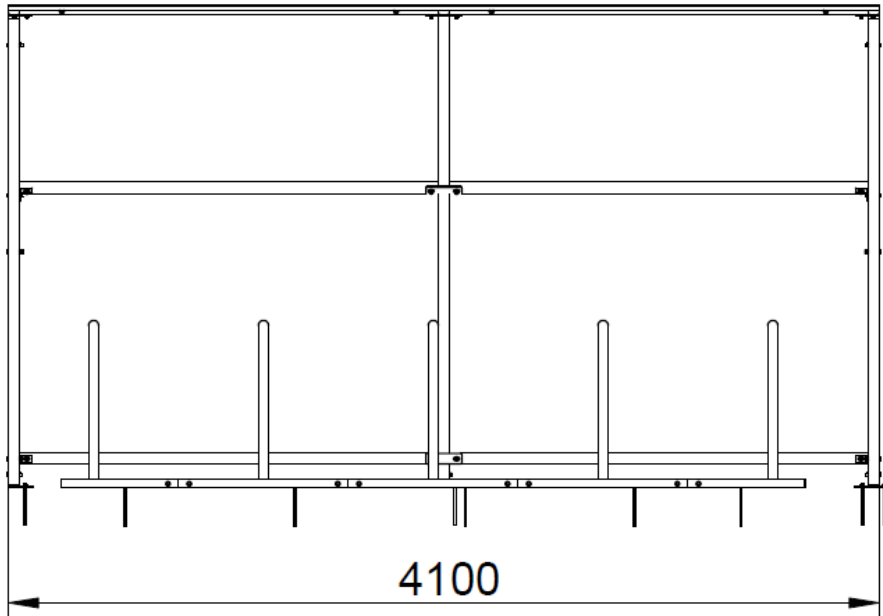

## Technical drawing

The Velo is manufactured in modules starting at 2.05m or 4.1m width. These can be increased in line with the number of cycles or scooters required to be stored.

Additional features such as hinged or sliding gates, or a compound design are also available.

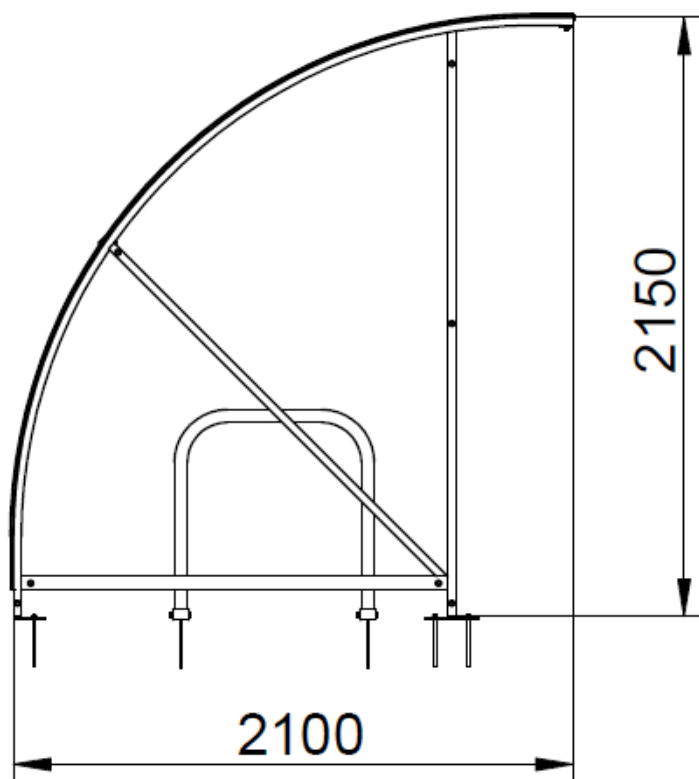

## Available options:

### - Choose Finish

- Galvanised only
- Powder Coat only
- Galvanised and Powder coated.

### - Fixing type

- Above Ground
- Below Ground

### - Pet-G Sheet Thickness

- 3mm Sheeting -

### - End Panels

- No End Panels
- 3mm End Panels
- 3mm Themed End Panels -
- 5mm End Panels -
- 5mm Themed End Panels

### - Cloaking

- No Cloaking
- Cloaking Set

### - Choose Gate Lock Option

- Hinged Gate, Standard Padlock -
- Hinged Gate, Manual Digital Lock -
- Hinged Gate, Swipe Card

### - Add Helmet Lockers

Standard Colour Chart

